

SSB Electric Steam Boilers

- All wetted metal parts are stainless steel.
- Passivation-Pressure Vessel per ASTM A-967-96
- **NOTE:** Water with a minimum of 1 meg ohm-cm specific resistivity must be used for proper & safe boiler operation.

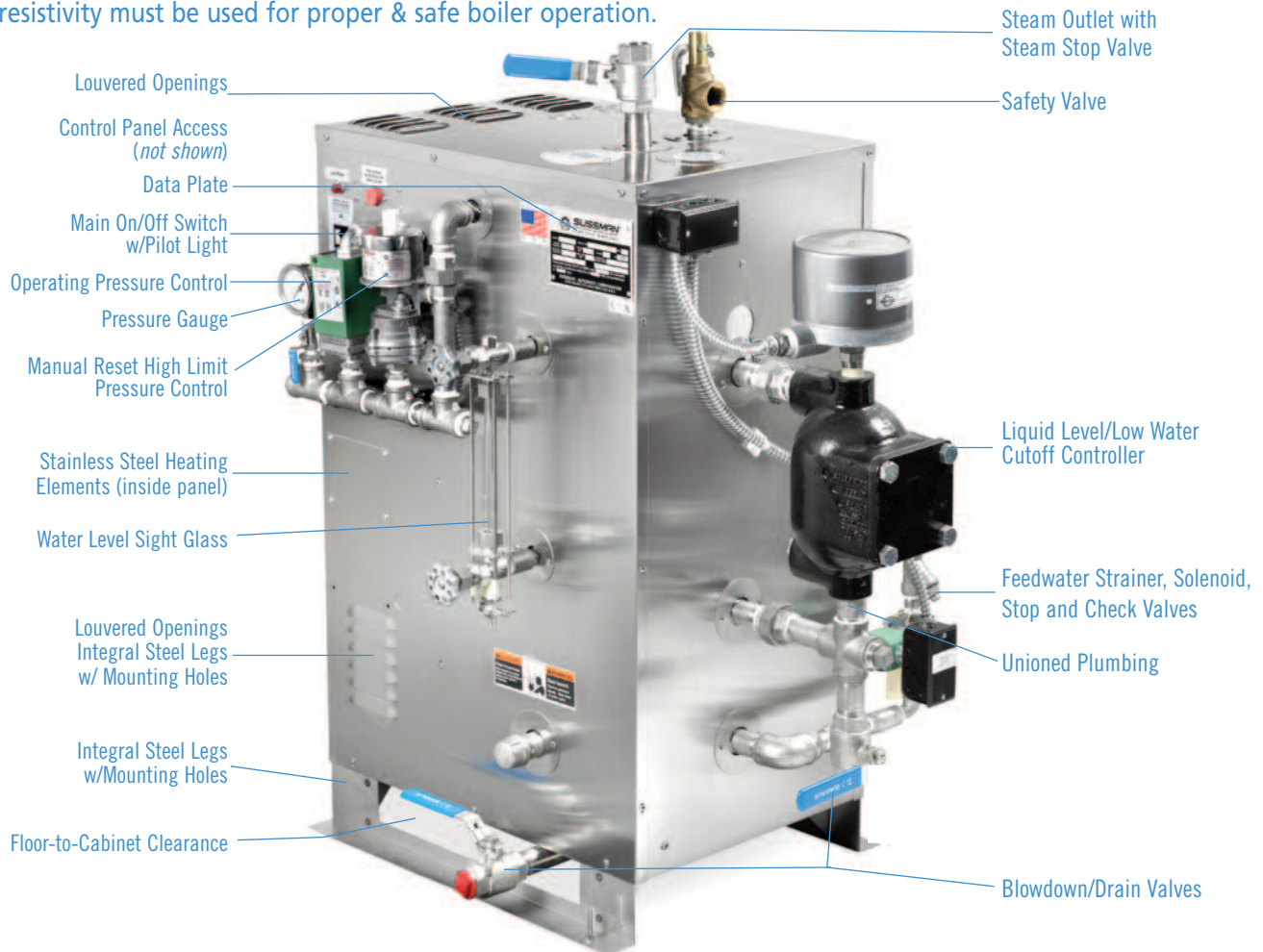

Built to ASME Code



Typical boiler arrangement

Stainless Steel Electric Boilers

Sussman SSB Boilers minimize contaminants because all-wetted metal parts are Stainless Steel. Whenever copper, iron or other materials cannot be tolerated in the steam and/or process, a Sussman SSB Stainless Steel Boiler is the product of choice for clean steam.

Designed for:

- Pharmaceutical, Chemical Process, Sterilization, Food Processing, Cosmetics, Autoclaves and other clean steam.
- Series 316L stainless steel pressure vessel.
- Passivation of pressure vessels and fittings
- Built to ASME Boiler and Pressure Vessel Codes Sect. I UL and cUL Listed. National Board registered.
- Tested to rigid Q.C. Inspection Procedures.

SSB-Standard Features

- **LOW WATER CUT-OFF/LEVEL CONTROL** Float type automatically maintains proper water level for safe operation and shuts off the boiler when the water supply falls below a safe level. Auxiliary low-water cut-off supplied in addition to primary control as standard
- **WATER LEVEL SIGHT GLASS** - Permits visual observation of water level while unit is in operation.
- **MAIN ON-OFF SWITCH** - Permits manual operation of boiler control circuit.
- **STEAM STOP-VALVE** - Ball valve; quick closing.
- **PILOT LIGHT** - Indicates boiler on/off condition.
- **INTEGRAL ELECTRICAL CONTROL** - Magnetic contactors for energizing boiler elements are integrally mounted in the control unit.
- **BLOWDOWN/DRAIN VALVES** - Permits easy blow-down and draining.
- **LONG LIFE HEATING ELEMENTS** - Industrial Grade heavy duty 0.420 inch diameter stainless steel sheath heating elements with one piece resistance welded terminations for added life and security.
- **OPERATING PRESSURE CONTROL** - Automatically maintains pre-set operating pressure within boiler.
- **RUGGED INDUSTRIAL CONSTRUCTION**
- **AUXILIARY LOW WATER CUTOFF**
- **PASSIVATION PER ASTM A-967-96**
- **NEMA 1 Louvered enclosure standard**
- **LINE PRESSURE WATER FEED** – used when incoming water pressure is at least 10 PSIG higher than operating pressure.

Meeting Code Requirements

- Built to ASME Section I for max 100 PSIG. Vessel National Board Registered. Code E certified
- Electrical construction conforms to NEC requirements.
- UL and cUL Listed.

Safety Features

- **STEAM SAFETY VALVE** - ASME Code Safety Valve automatically opens to reduce pressure.
- **STEAM PRESSURE GAUGE** - Allows visual observation of steam while unit is in operation.
- **MANUAL RESET PRESSURE CONTROL** - Provides high limit pressure cut-off with manual reset feature.

SSB Electrical Steam Boiler

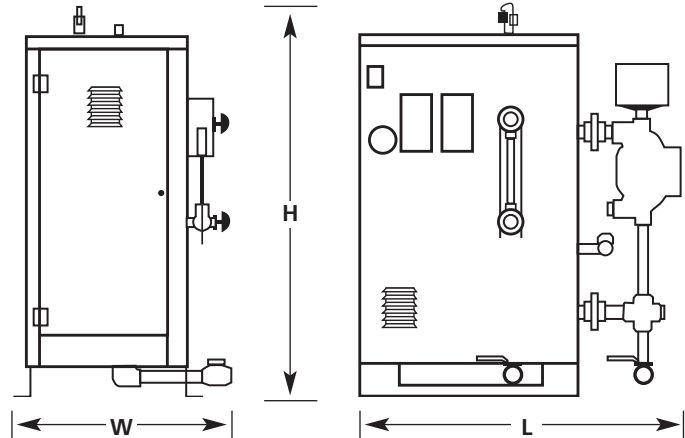

Boiler Model	KW	BHP	Steam Lbs/Hr ##	3 Phase Voltage	Total Amps	W L H Inches	Ship Wt.
SSB-12*	12	1.22	36.2	208	34	20 28 36	260
				240	29		
				480	15		
SSB-18*	18	1.84	54.2	208	50	20 28 36	270
				240	44		
				480	22		
SSB-24*	24	2.45	72.3	208	67	27 33 45	330
				240	58		
				480	29		
SSB-30*	30	3.06	90.4	208	84	27 33 45	340
				240	73		
				480	37		
SSB-36*	36	3.67	108	208	100	27 33 45	350
				240	87		
				480	44		
SSB-48	48	4.89	145	208	128	27 33 45	365
				240	111		
				480	56		
SSB-60	60	6.12	181	208	167	27 33 45	410
				240	145		
				480	73		
SSB-72	72	7.35	217	208	200	27 33 45	420
				240	174		
				480	87		
SSB-85	84	8.50	256	208	236	28 34 59	675
				240	204		
				480	102		
SSB-100	108	11.0	325	208	284	28 34 59	675
				240	246		
				480	123		
SSB-135	144	14.6	433	208	400	30 36 61	785
				240	347		
				480	173		
SSB-160	158	161	475	240	379	30 36 61	785
				480	190		
				240	434		
SSB-180	180	18.4	542	480	217	30 36 61	790

* Single phase available

Other voltages available: 380/415/600, 50Hz

With 50°F feedwater

NOTES:

- All wetted metal parts are stainless steel. Consult factory for specific wetted parts materials.
- Allow 21 inches for heating element removal. When ordering: Specify model number, kw, volts, phase and optional equipment.
- Minimum of 1 meg ohm-cm specific resistivity feed water must be used for proper & safe boiler operation